

## How To Work A Cavetto

A basic segmental cavetto moulding is formed out of a quarter circle, radius  $a-b$ .

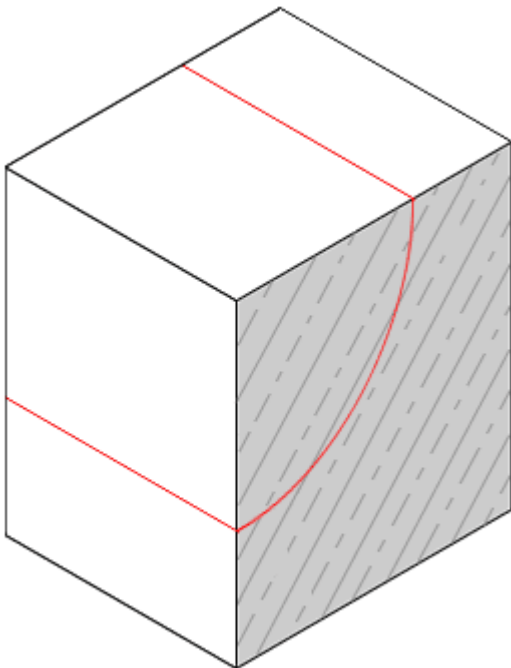
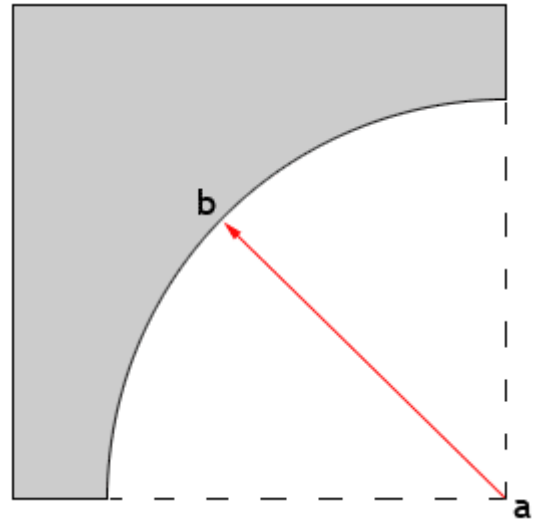

The process of working a cavetto begins by marking the template onto the parallel joints of the stone using a scribe. Templates for stone are traditionally made from zinc sheeting.

With the template marked on, chamfers are worked from each side of the moulding towards the middle. This stage defines the deepest part of the mould, and like all stonework, using a straight edge ensures the mould remains true through the length of the stone with no high or low spots.

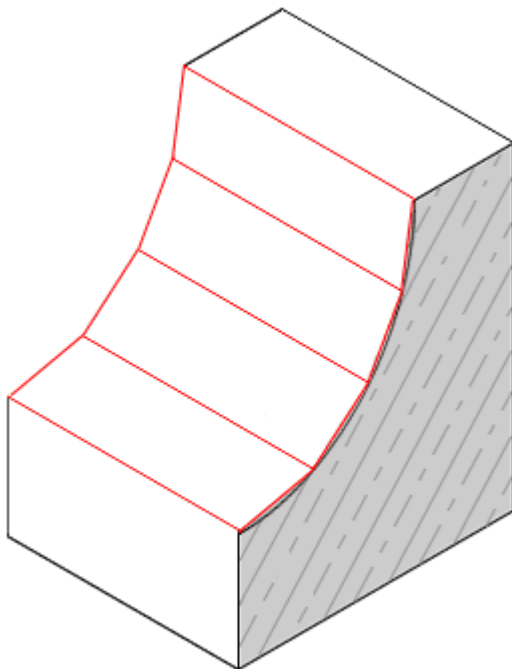
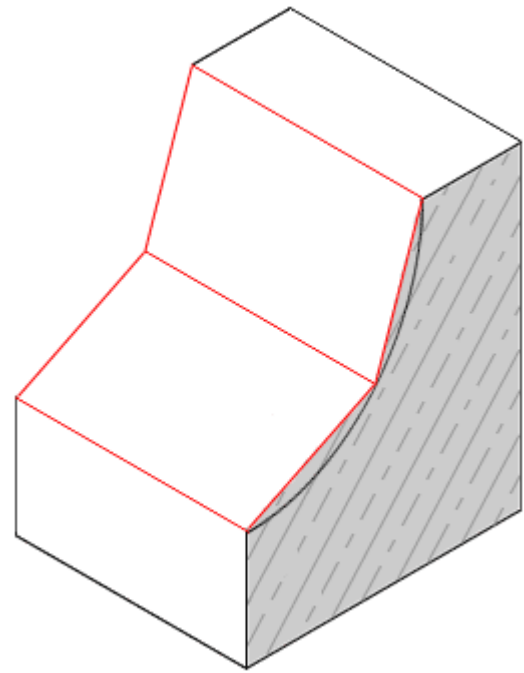

Following on from the previous stage the process is repeated to define two more points of the mould. Again, checked with a straight edge.

The final process of defining the curve is done with a bullnose using the points at which the previous chamfers meet as guides. Using the bullnose the curve is worked along its length and checked with a straight edge for trueness. With the curve now worked it is tooled over with a dummy and bolster following the curve of the mould to remove any flat spots.

